



T-Pact Moulded Case Circuit Breaker

1. General

- 1.1 Certificates: KEMA,CB;
- 1.2 Electric ratings: AC50/60Hz, AC220V~690V
DC250V~500V, 16A~1250A;
- 1.3 Standard: IEC/EN 60947-2.
- 1.4 For detailed certificate, please refer to P116.

2. Type Designation

T-Pact \.....

Fixed or Plug-in
Fixed:Blank
Plung-in :W

Type of release:
TM:Blank
Electronic:E

Number of poles:
2:2 Pole
3:3 Pole
4:4 Pole

41: Without current release components, N-pole makes with other three poles (N-pole first makes then breaks)

42: With current release components, N-pole makes and breaks with other three poles, N-pole first makes then breaks, N-pole operating value is 1.0In of other three poles

43: With current release components, N-pole makes and breaks with other three poles , N-pole operating value is 0.5In of other three poles

Breaking capacity code:
S:standard
H:Higher type/R:Current limiting type

Relay rated current:16 upto 1250A

Frame size rated current:125,250,630 and 1250

Type name







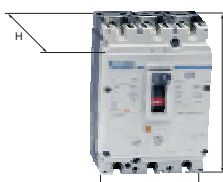

3. Operation Conditions

- 3.1 Temperature: -5°C~+40°C; the average value within 24h shall not exceed +35°C; for the circuit breaker with thermo-magnetic release, +40°C is set to be the standard temperature for ratings. Special utilization, please refer to coefficients indicated on page 25 for temperature compensation correction;
- 3.2 Altitude: ≤2000m;
- 3.3 Pollution grade: Grade 3;
- 3.4 Air conditions:
At mounting site, relative humidity not exceed 50% at the max temperature of +40°C, higher relative humidity is allowable under lower temperature. For example, RH could be 90% at +20°C, special measures should be taken to occurrence of dews.

5. Technical Data

5.1 Parameters

T-Pact circuit breaker Thermal-magnetic type		T-Pact 125						T-Pact 250					
4 Frames		Frame 1						Frame 2					
Electric characteristics as per IEC 60947-2 and EN60947-2													
Rated current(A)	I_n	16, 20, 25, 32, 40, 50, 63, 80, 100, 125						100, 125, 160, 180, 200, 225, 250					
Rated insulation voltage (V)	U_i	750						750					
Rated impulse withstand voltage (kV)	U_{imp}	8						8					
Rated operational voltage (V)	U_e	AC 50/60Hz						690					
		DC						500					
Number of poles		2		3		4		2		3		4	
													
Breaking capacity code		H		S		H		S		H		S	
Rated ultimate short-circuit breaking capacity (kA RMS) I_{cu}	AC 220V/230V/240V	100	85	100	150	85	100	100	85	100	150	85	
	AC 380V/400V/415V	100	50	100	150	50	100	100	50	100	150	50	
	AC 440V	100	50	100	130	50	100	100	50	100	130	50	
	AC 500V	50	35	50	70	35	50	50	35	50	70	35	
	AC 660V/690V	6	5	6	8	5	6	8	6	8	10	6	
	DC 250V (1P)	35	25	35	50	25	35	35	25	35	50	25	
DC 500V (2P)	35	25	35	50	25	35	35	25	35	50	25		
Rated service breaking capacity I_{cs} =(% I_{cu})		100						100					
Suitability for isolation		■						■					
Utilization category		A						A					
Safety of insulation		■						■					
Life(CO recycle)	Mechanical	20,000						20,000					
	Electrical	20,000						20,000					
Protection		Thermo-magnetic						Thermo-magnetic					
Release units		■						■					
Over-load protection		■						■					
Short-circuit protection		■						■					
Residual current protection	Added on residual current protection module	-						-					
Mounting and connection													
Fixed	Front connection	■						■					
	Rear connection	■						■					
DIN rail	Front connection	■						■					
	Plug-in	■						■					
Manual	Front connection	■						■					
	Rear connection	■						■					
	Handle	■						■					
Motor-driven mechanism		■						■					
Manual, remote operated automatic source changeover systems		■						■					
Shunt and under-voltage release		■						■					
Auxiliary and alarm contact		■						■					
Pad locking system		■						■					
Mounting and connection accessories													
Connection terminal		■						■					
Front connection plate		■						■					
Rear connection plate		■						■					
DIN rail adaptor		■						■					
Plug-in type connection accessories		■						■					
Terminal covers		■						■					
Interphase barrier		■						■					
Dimension and weight													
Dimension(mm)W H L	Fixed type-front connection	62 140 79	90 140 79	120 140 79	70 157 88	105 157 88	140						
Weight(kg)	Fixed type-front connection	0.85	1.2	1.6	1.5	2.1							

Note: ① When U_e is $\geq 660V$, $I_{cs}=50\% I_{cu}$.

Dimension

Overall Dimensions of fixed type

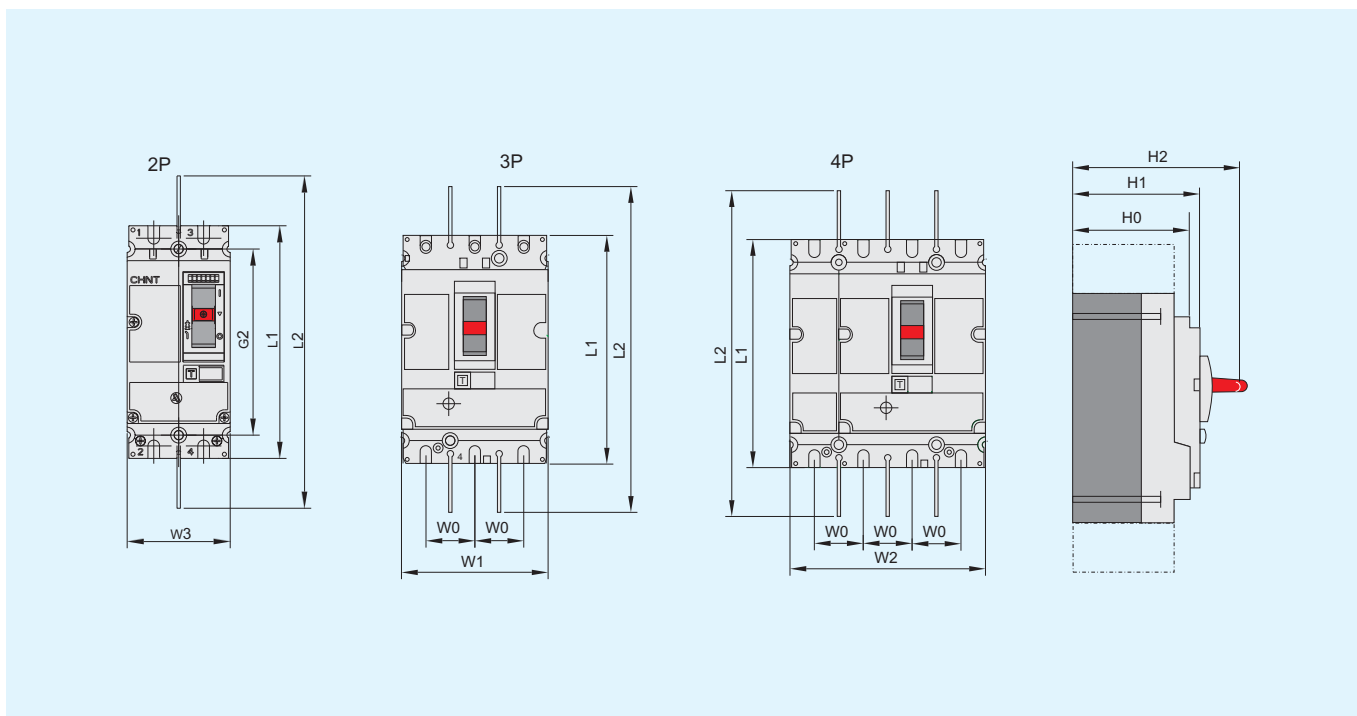

	L1	L2	H0	H1	H2	K	K1	K2	G1	G2	W0	W1	W2	W3	d
T-Pact 125	140	240	72	79	103	15	30	60	56	112	30	90	120	62	6
T-Pact 250	157	357	82	88	126	17.5	35	70	62.5	125	35	105	140	70	6
T-Pact 400, 630	255	474	95	113	168	22.5	45	90	100	200	45	140	185	-	6
T-Pact 800, 1250	370	570	132	144	206	35	70	140	120	240	70	210	280	-	7

Overall and mounting dimensions of fixed type for rear connection

Overall dimension of plug-in type

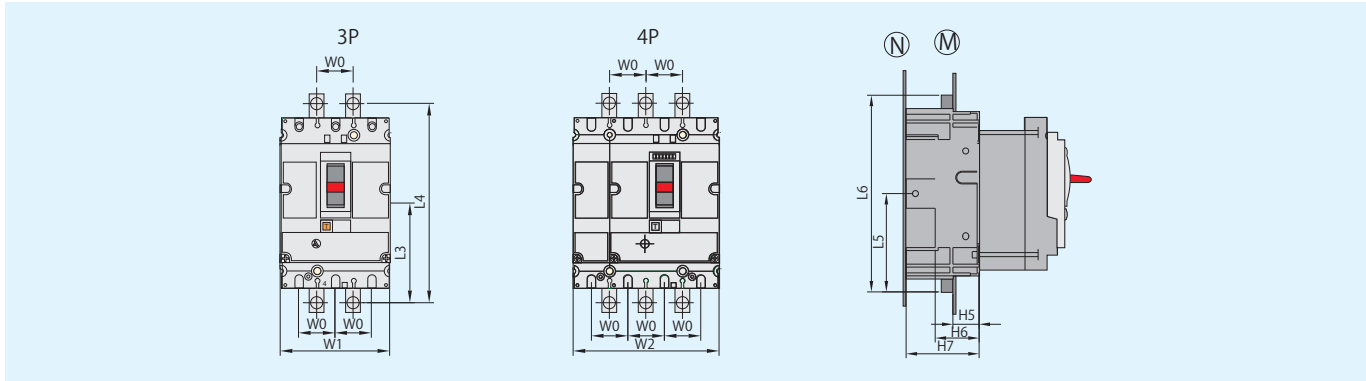

(mm)

	W0	W1	W2	L5	L6	H5	H6	H7
T-Pact 125	30	90	120	90	180	24	40	67
T-Pact 250	35	105	140	102.5	205	27	45	75
T-Pact 400, 630	45	140	185	157.5	315	27	45	45

7.2 Temperature compensation

When the ambient temperature slightly changes, tripping characteristics will change as well, please refer to the table below for temperature compensation correction.

7.2.1 Temperature compensation coefficient of breaker with thermo-magnetic release as follows.

Ambient temperature	-40°C	-35°C	-30°C	-25°C	-20°C	-15°C	-10°C	-5°C
Temperature compensation coefficient	1.4	1.375	1.35	1.325	1.3	1.275	1.25	1.225

Ambient temperature	0°C	5°C	10°C	15°C	20°C	25°C	30°C	35°C	40°C	45°C	50°C	55°C	60°C	65°C	70°C
Temperature compensation coefficient	1.2	1.175	1.15	1.125	1.1	1.075	1.05	1.025	1.0	0.975	0.95	0.925	0.90	0.875	0.85